

# Lines

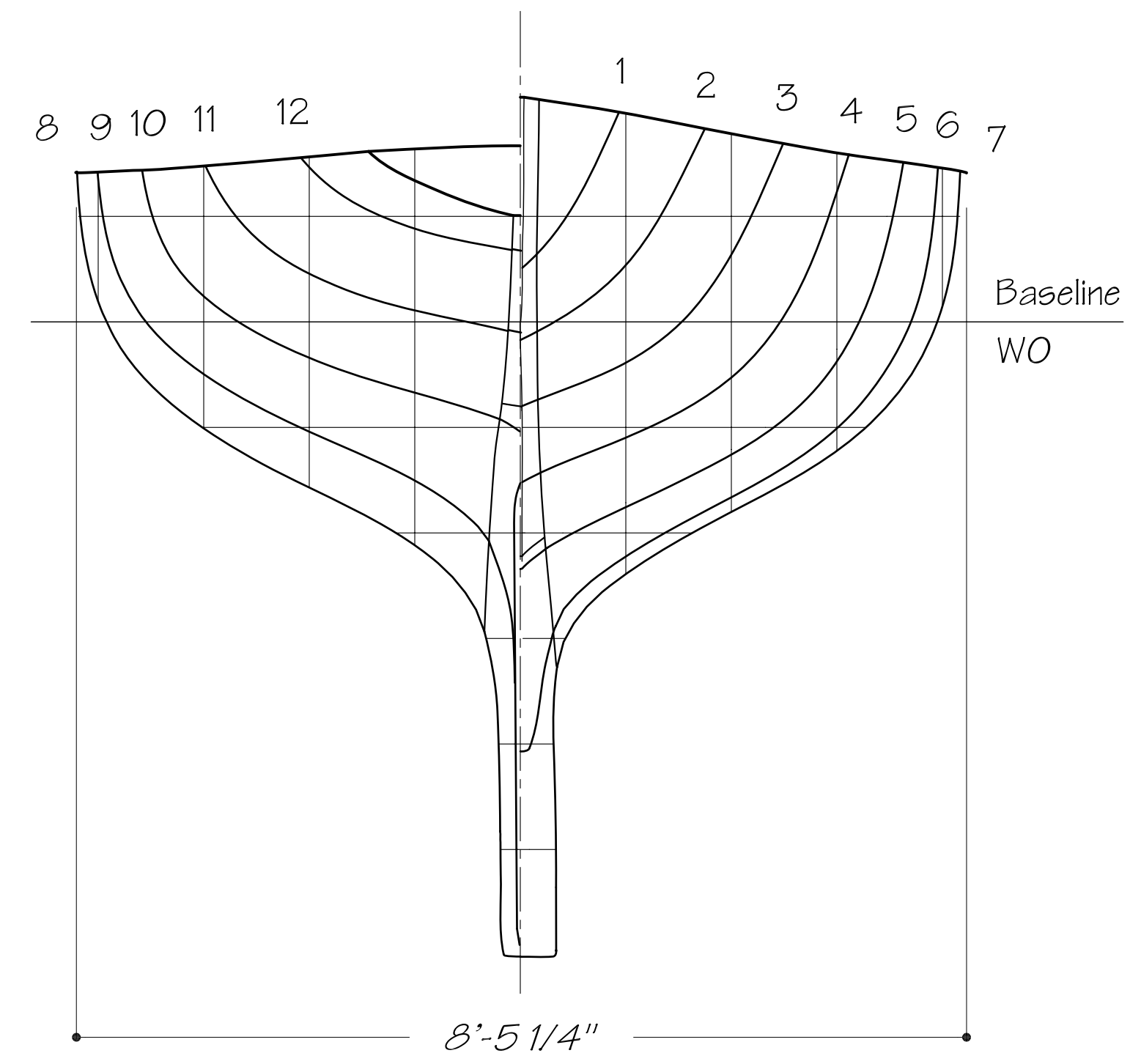

**TABLE OF OFFSETS**  
 OFFSETS IN FEET - INCHES - EIGHTHS    OFFSETS ARE TO OUTSIDE OF SKIN

STATIONS	0.000	1.000	2.000	3.000	4.000	5.000	6.000	7.000	8.000	9.000	10.000	11.000	12.000
X-POSITIONS	0- 0-0	3- 0-0	6- 0-0	9- 0-0	12- 0-0	15- 0-0	18- 0-0	21- 0-0	24- 0-0	27- 0-0	30- 0-0	33- 0-0	36- 0-0
BUTTOCK 0- 0-0			-0- 2-0+										
BUTTOCK 1- 0-0			0- 6-3+	-0- 4-5	-1- 1-1	-1- 9-0+	-2- 2-5+	-2- 4-5+	-2- 1-3+	-1- 6-0+	-0- 8-0+	0- 1-2+	0-10-5
BUTTOCK 2- 0-0				0- 7-5	-0- 6-2+	-1- 3-1	-1- 7-7+	-1- 9-5	-1- 6-6+	-1- 0-4	-0- 4-0+	0- 5-4	1- 5-4+
BUTTOCK 3- 0-0					1- 2-6+	-0- 4-4	-1- 0-0+	-1- 2-5+	-1- 0-0+	-0- 5-7+	0- 2-7+		
BUTTOCK 4- 0-0								0- 1-7	0- 2-3	1- 4-2			
SHEER	2- 1-4+	1-11-6+	1- 9-7+	1- 8-2	1- 6-7+	1- 6-1	1- 5-4+	1- 5-1	1- 4-7+	1- 5-0	1- 5-2	1- 5-6	1- 6-4
RABBET		0- 8-0	-0- 0-7+	-0- 8-7	-1- 5-0	-2- 1-6+	-2-11-0	-3- 3-1	-2-11-2+	-2- 0-5	-0-11-0+	-0- 0-6+	0- 8-1+
KEEL	2- 1-4+	0- 6-1	-0- 2-1+	-0- 9-4+	-1- 6-2	-2- 4-6	-4- 0-6	-6- 0-0	-5-11-6+				
WL 1- 0-0		0- 5-2+	1- 3-7+	2- 2-2	2-11-0+	3- 6-3	3-11-0	4- 1-6	4- 2-0+	3-11-3+	3- 5-6+	2- 8-2+	1- 3-6
WL 0- 0-0			0- 3-7	1- 6-2+	2- 5-4+	3- 2-4	3- 8-3+	3-11-3	3-11-0	3- 6-4+	2- 8-0+	0- 6-0	
WL -1- 0-0					1- 2-5	2- 4-6+	3- 0-0+	3- 3-2	3- 0-1	2- 1-0+	0- 0-5		
WL -2- 0-0						0- 6-0	1- 4-3+	1- 7-4+	1- 2-1	0- 4-1+			
WL -3- 0-0							0- 3-4+	0- 5-1	0- 3-7	0- 0-6+			
WL -4- 0-0								0- 1-1+	0- 3-6+	0- 2-3+			
WL -5- 0-0								0- 4-0+	0- 2-2	0- 0-3			
SHEER	0- 0-3+	0-11-2+	1- 9-1	2- 6-0+	3- 1-6	3- 7-5	3-11-5+	4- 2-1+	4- 2-5	4- 0-2	3- 7-0	3- 0-0+	2- 2-0
RABBET		0- 1-7	0- 1-7+	0- 2-0	0- 2-2+	0- 2-7	0- 3-6	0- 4-1+	0- 3-7+	0- 3-3	0- 2-3+	0- 1-2+	0- 0-7+
KEEL	0- 0-3+	0- 0-2	0- 0-1	0- 0-2	0- 0-1+	0- 0-1+	0- 0-4	0- 3-3+	0- 1-6+				

NOTES: MEASUREMENTS WERE TAKEN USING A LEICA TCR303 "TOTAL STATION" AND DEVELOPED IN AEROHYDRO MULTISURF.  
 STATIONS ARE OFFSET IN 3-FOOT INTERVALS. LINES ARE DRAWN AS IS AND NOT FAIRED. ACCURACY IS +/- 1/2 INCH.

